



## a.b.e.<sup>®</sup> Construction Chemicals **METHODOLOGY** **abe.<sup>®</sup> flo HPU**

### **OLD CONCRETE**

The surface has to be clean, sound, dry and free of oil and deleterious matter prior to applying the system.

### **NEW CONCRETE**

The surface has to be clean, sound, dry and free of oil and deleterious matter prior to applying the system.

The surface must be finished such that all the falls are correct and ready to receive the polyurethane screed system. The success of any application depends on the strength of the concrete surface. A simple but effective test can be done with the use of an Elcometer adhesion tester. The pull off value when testing concrete should be equal to or greater than 1,5MPa. Levels below this indicates a relatively weak surface and could affect the performance of the screed.

### **INSTALLATION CRITERIA:**

#### **Substrate requirement**

A minimum of 25 MPa cured concrete or screed laid true to line and level, clean, dry and free of laitance having a smooth wood floated finish. Granolithic screed thickness to be a minimum of 40mm. No concrete curing agents or dry cement slurries to be used as a final finish to screeds. **abe.<sup>®</sup> flo HPU** to be applied at material temperatures between 12°C and 18°C and ambient temperatures of 5°C to 30°C. Relative humidity of substrate is not to exceed 75%. Temperature is not to be below 5° during the 24 hour cure period.

#### **Surface preparation**

Preparation to be by Vacu-Blasting with steel shot or by scarification to expose aggregates. Anchor grooves of a minimum dimension of 4mm x 4mm to be provided for at all perimeter edges, around columns and doorways, at drains and on each side of bay joints. All residual preparation contaminants to be removed to provide a dry, dust free surface. The substrate must be dry before application. We suggest that an electronic moisture content test be conducted prior to the application of the priming system. A Protimeter Survey Master or equivalent can be used for this purpose. Maximum moisture content should be between 4% and 6%.

#### **Surface repair**

Surface repairs up to 20 mm thickness are to be undertaken using **abe.<sup>®</sup> screed SLC P** (fast track screed) while repairs above this thickness can be effected with **dura.® latex** polymer reinforced concrete or screed system. Repairs must be allowed to dry.

#### **Substrate movement**

Any joints or cracks in the concrete substrate, which are subject to thermal movement, will be reflected in the **abe.<sup>®</sup> screed PU** screed. These joints must be carried through the **abe.<sup>®</sup> screed PU** screed by cutting and sealing with a flexible sealant suitable to the operational demands of the area. Areas around ovens or cold rooms are to be isolated from the surrounding floor by an expansion joint.

#### **Priming**

Note: **PU/HPU Primer** is a 3 component system consisting of a base & activator and a fine agg. Prior to the application of **abe.<sup>®</sup> flo HPU** the surface must be primed with **PU/HPU Primer**. The primer coat should be allowed to dry for a minimum of 12 hours. Priming can only be omitted on surfaces with a suitable proven density. However, it is best practice to prime any surface prior to the application of a coating or screed. Being moisture tolerant **abe.<sup>®</sup> flo HPU** can also be applied to slightly damp surfaces.

#### **Coved skirting and vertical surfaces**

Coved skirtings 10 mm thick x 200 mm x height x 100 mm width are to be formed and vertical surfaces are to be covered using **abe.<sup>®</sup> screed PU** coving grade. **abe.<sup>®</sup> screed PU CG**. The **abe.<sup>®</sup> screed PU** coving grade has to be applied whilst the primed surface is still tacky. The tacky period is approximately 5 hours. Do not scatter silica sand on the primed surface as this will affect the adhesion. A spread rate of 8m<sup>2</sup>/l using **PU/HPU Primer** is achievable.

### Mixing

**abe.®flo HPU** kit components are pre-weighed and kits should never be split. The material must be used as supplied in kit form and not substituted with an alternative. A suitable pan mixer with a speed of 80 to 120 rpm is required. Charge pan with base component. Add the hardener component to the base component and mix for at approximately 30 seconds taking care not to entrain air. Add the aggregate component and mix for a minimum of 3 minutes ensuring a uniform mix. Always ensure residue from the previous mix is removed from both sides of the drum before re-charging the mixer.

### Coverage

7,6 kg/m<sup>2</sup> at 4 mm (no wastage)

### Application

Within one minute after mixing, spread the topping onto the primed floor to the required thickness using a steelbladed trowel, or an adjustable pin spreader (800 mm) rake set to the correct depth. Within 3 minutes of application, roll with a spiked roller. Lay abutting mixes within 3 minutes of application of previous mix. Maximum bay width is 5 m.

### PROTECTION ON COMPLETION

If time constraints (or any other) results in application of the screed being short of the anchor grooves then new grooves need to be cut to finish off the application. New grooves need to be cut prior to the new application. Protect the surface and ensure no traffic or spillage for 24 hours after installation.

### EQUIPMENT CLEANING

Clean tools and equipment with **abe.® super brush cleaner** before the material has cured.

### IMPORTANT NOTE

This method statement is issued as a guide to the use of the product(s) concerned. Whilst **a.b.e.® Construction Chemicals** endeavours to ensure that any advice, recommendation, specification or information is accurate and correct, the company cannot – because **a.b.e.®** has no direct or continuous control over where and how **a.b.e.®** products are applied – accept any liability either directly or indirectly arising from the use of **a.b.e.®** products, whether or not in accordance with any advice, specification, recommendation or information given by the company.

### FURTHER INFORMATION

Where other products are to be used in conjunction with this material, the relevant technical datasheets should be consulted to determine total requirements. **a.b.e.® Construction Chemicals** has a wealth of technical and practical experience built up over years in the company's pursuit of excellence in building and construction technology.

### abe.®flo HPU JOINT DETAIL

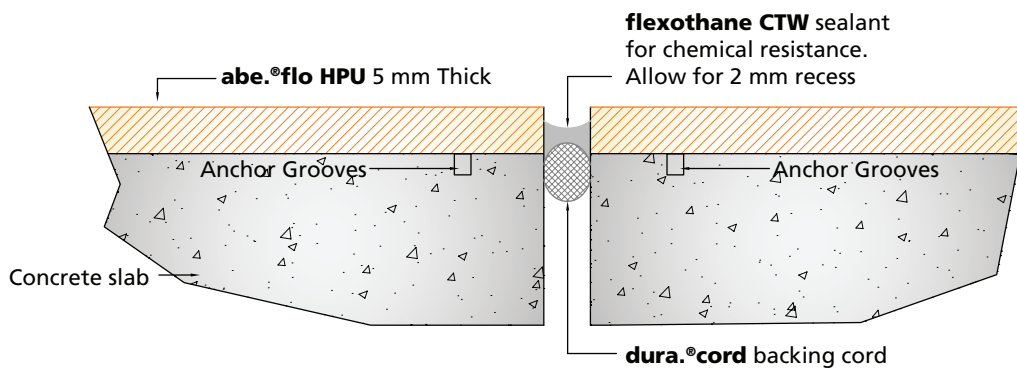

a.b.e.® is an ISO 9001:2008 registered company  
PO Box 5100, Boksburg North, 1461, South Africa  
Website: [www.abe.co.za](http://www.abe.co.za) | Tel: +27(0) 11 306 9000  
Durban | Johannesburg | Cape Town | Port Elizabeth | East London | Bloemfontein | George

a.b.e.® is a Chryso Group Company

**CHRYSO**  
CHEMICAL SOLUTIONS FOR THE  
CONSTRUCTION MATERIALS INDUSTRY

## EDGE OF SLAB

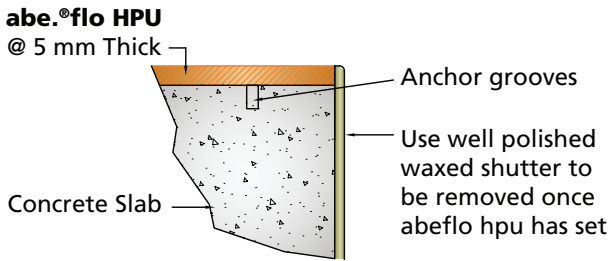

## SLAB TO WALL JOINT

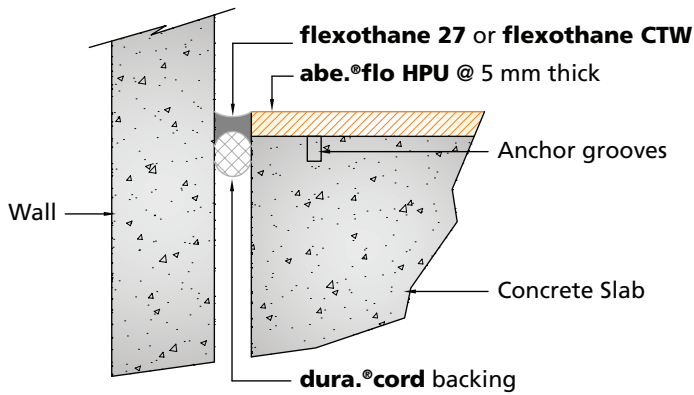

## STEEL PLATE TO FLOOR SLAB

